

OPERATING INSTRUCTION OIL SAFETY AND SHUT-OFF BLOCK SABX3-10

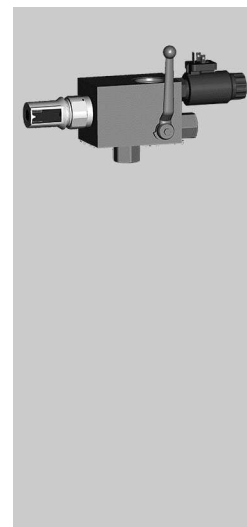

Designs of release:

M
Manual release

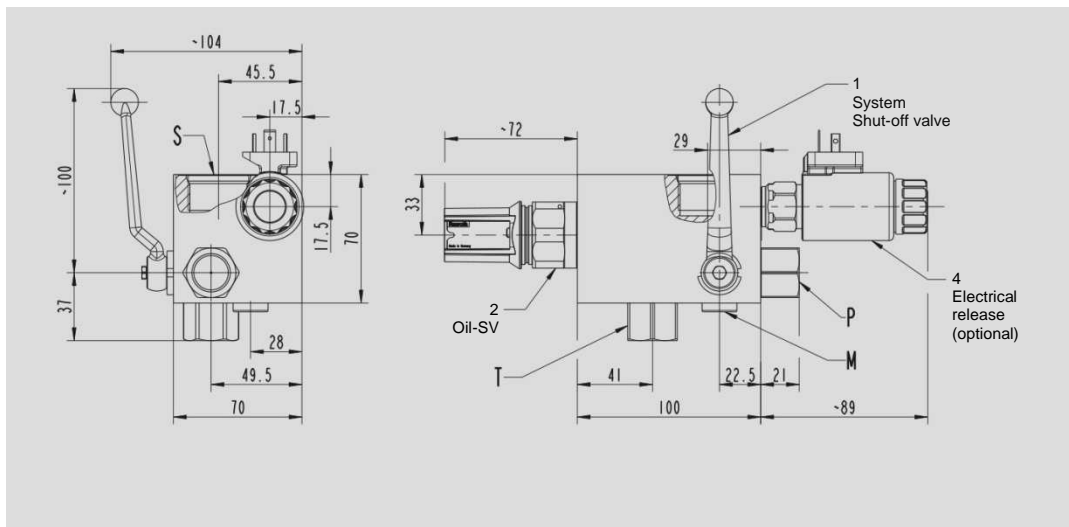
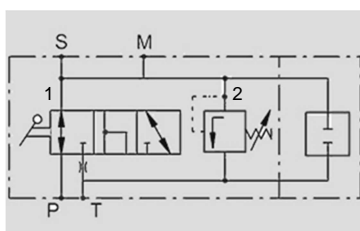

EO
Electrical, power-off open

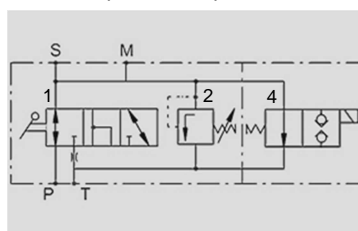

EG
Electrical, power-off closed

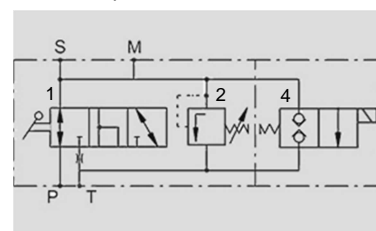

Technical data:	
Nominal diameter (DN):	10 mm
Working pressure (PS):	max. 500 bar (Design EO / EG max. 350 bar)
Working medium:	Mineral oil according to DIN 51524 part 1 and 2
Bloc material:	Steel; ZINi coating
Working temperature (TS):	-10 ... + 80°C (other on request)
Acceptance regulation: *	PED 2014/68/EU (article 4, paragraph 3)
Sealing material:	Standard FKM / POM (other on request)
Plug-in connector:	DIN EN 175301-803
Viscosity:	>10mm ² /s, < 380mm ² /s
Supply voltage:	24 VDC / 22 W (other on request)
Protection type:	IP65
Connection bores:	Accumulator connection: S = M33 x 2 (DIN 3852-3)
	Measuring connection: M = G 1/4" (DIN EN ISO 228-1)
	Pump connection: P = G 1/2" (DIN EN ISO 228-1)
	Tank connection: T = G 1/2" (DIN EN ISO 228-1)

* Oil safety valve with CE marking

The SAB serves as a device for the protection, shut-off and discharge of hydro accumulators. It is designed according to PED 2014/68/EU, article 4 paragraph 3, manufactured and considered to the European safety regulations for the operation of hydraulic accumulators, provided that the discharge capacity of the oil safety valve (see operating instruction of oil safety valve) is not less than the installed capacity of the pressure generator.

The oil safety and shut-off block type SABX3-10 is designed for a maximum working pressure (PS) of 500bar. The different setting pressures for the oil safety valve (pos. 2) should be selected depending on the working parameter. The setting pressure of the oil safety valve (pos. 2) is marked on the nameplate.

Designs of release

Manual release (M):

The manual release of the accumulator is carried out by switching of the system shut-off valve (pos. 1). In this case the accumulator is directly relief to the tank. When switching of the system shut-off valve (pos. 1) the connections P, S and T are connected for a short time with each other because of the L ball (negative overlap).

Electrical release (EO / EG):

The discharge of the accumulator is in addition to the manual release via an electromagnetic 3/2 way poppet valve (pos. 4). There are two versions available, normally open (EO) or normally closed (EG).

If the SAB is a component of an assembly, the operation parameter of the separate components are to be verified (particularly temperature, fluid group and pressure) before take into operation of the assembly. Also the manual for the hydraulic accumulator is taken under consideration.

To avoid destruction of the sealing shells of the ball valve, the ball valves should be opened / closed quickly to the stop.

The seals have to be chosen according to the used medium.