

**OPERATING INSTRUCTION
N2 CHARGING UNIT**

Type: BA-AGGR-CE-EN-36X5095

Language: English

Edition: 10-2021

Revision: 00

Translated from German original



General

Roth pressure equipment – Identification

in accordance with the serial number on the nameplate and the according report, see

- Acceptance report, Pressure Equipment Directive 2014/68/EU
TÜV Technische Überwachung Hessen GmbH

Translation

If sold to a country in the EEA, this operating instruction must be translated into the language of the country in which the machine is to be used.

Should the translated text contain incongruities, the original operating manual (German) must be consulted or the manufacturer contacted for clarification.

Copyright

No part of this publication may be reproduced, transmitted, sold or communicated without prior permission. Damages will be claimed for violations.

All rights reserved.

Notes

The following Roth operating instructions are required and supplementary to this one:



Operating instruction Roth piston accumulator

BA-AK-CE-EN

Operating instruction Roth filling and testing device

BA-FPE-EN

0 Contents

0.1 Table of Contents

| | | |
|-------|---|----|
| 0 | Contents | 1 |
| 0.2 | Table of figures | 1 |
| 1 | Designated application | 2 |
| 1.1 | Figure of Roth N2 charging unit | 2 |
| 1.2 | Notes on designated application / description | 2 |
| 2 | Technical specifications | 3 |
| 3 | Overview Roth N2 charging unit | 4 |
| 4 | Function principle | 8 |
| 5 | Safety | 9 |
| 5.1 | Notes / Explanations | 9 |
| 5.2 | Identification / Nameplate | 9 |
| 5.3 | Safety systems | 10 |
| 5.3.1 | Safety components on gas side | 10 |
| 5.3.2 | Safety components on oil side | 10 |
| 5.4 | Safety precautions | 10 |
| 5.5 | Responsibilities of the operator | 10 |
| 6 | Dangers | 11 |
| 6.1 | General hazard notes | 11 |
| 6.2 | Installation of spare and wearing parts | 11 |
| 6.3 | Cleaning, maintenance and repair work | 11 |
| 7 | Commissioning | 12 |
| 7.1 | Filling process preparations | 12 |
| 7.2 | Filling process | 14 |
| 7.2.1 | Isochore behavior of N2 | 16 |
| 7.3 | Completing the filling process | 17 |
| 8 | Storage | 18 |
| 9 | Maintenance | 19 |
| 9.1 | General maintenance notes | 19 |
| 9.2 | Initial operating, repeated inspection and periods of repeated inspection | 19 |
| 10 | Disassembling / disposal | 20 |
| | Notes | 21 |

0.2 Table of figures

| | | |
|------------|--|----|
| Figure 1-1 | Figure Roth N2 charging unit | 2 |
| Figure 3-1 | Overview of Roth N2 charging unit | 4 |
| Figure 3-2 | Roth N2 charging unit hydraulic flow diagram | 5 |
| Figure 3-3 | Roth N2 charging unit electrical flow diagram page 1 of 2 | 6 |
| Figure 3-4 | Roth N2 charging unit electrical flow diagram page 2 of 2 | 7 |
| Figure 3-5 | Overview of Roth N2 charging unit operating elements | 8 |
| Figure 7-1 | Connection view for nitrogen bottle and accumulator / unit | 12 |
| Figure 7-2 | Isochore behavior of N2 | 16 |

1 Designated application

1.1 Figure of Roth N2 charging unit



Figure 1-1 Figure Roth N2 charging unit

1.2 Notes on designated application / description

The Roth N2 charging unit works automatically until a pre-set pressure is reached (P_0). It enables efficient loading or refilling of hydraulic accumulators, such as Roth piston, bladder, diaphragm accumulators or pressure vessels / units, beyond the overflow (natural pressure equalization) and thus enables almost complete emptying of commercial nitrogen bottles. Hydraulic accumulators / units can be filled up to 230 or 380 bar. Nitrogen (N₂) Class 4.0 (99.99%) or better shall be used.



Never use oxygen or other flammable gases for filling on the gas side.

The N₂ charging unit is compact and can be transported and operated by only one person. In combination with the Roth filling and testing device, the Roth N₂ charging unit is compatible with all filling connections worldwide.



The Roth filling and test unit (shown in Fig. 1-1) does not form part of the Roth N₂ charging unit. It is available as a separate accessory.

The N₂ charging unit is only intended to be connected to a hydraulic accumulator/system in order to adjust/set the gas fill pressure (P_0). After adjusting/setting P_0 , the N₂ charging unit must be disconnected from the hydraulic accumulator/system.

If permissible load cycling are specified for specific pressure ranges in the acceptance documentation, the operator is responsible for compliance. If the pressure equipment is operated with different operating parameters, it is possible that the test intervals for periodic tests will become shorter. Please consult the manufacturer in such cases.

Furthermore, the operator is obliged to adhere to the legal state regulations according pressure equipment's in connection with the adherence of the mandatory tests prior to commissioning and recurrent tests and must arrange these in compliance with the mandatory periods (see part 5.5).

An internal test must be performed by an authorised inspection body (see AD 2000 leaflet p2, 12.3) on all pressure equipment with a specified number of permissible load cycles (load cycling number "N" for the defined pressure range $p_{\min} - p_{\max}$) no later than when 50% of the permissible number of cycles have been completed. The specialist may then define the extended number of load cycles. The term for permissible load cycles $> 2\ 000\ 000$ is fatigue strength. Pressure equipment may be operated without restriction in this pressure range.

2 Technical specifications

| Technical specifications Roth N2 charging unit | |
|--|---|
| Dimensions [mm] | Length= 445, width=650, hight=970 |
| Weight [kg] | 85 |
| Transport and operation | Mobile, one person |
| Operating pressure [bar] | 250 / 420 |
| Max. N2 filling pressure (outlet) [bar] | 230 / 380 |
| Volume flow [l/min.] | 1,7 / 0,9 |
| Tank size | NG 12 |
| Tank filling capacity [l] | 10 |
| Volume piston accumulator [l] | 1,7 |
| Power [kW] | 0,75 |
| IP protection | IP 55 |
| Electrical connection | CEE 5-polig, 16A, 400 V – 50 Hz (other available on request) |
| Cable length [m] | 5 |
| Acceptance pressure device | DGR 2014/68/EU |
| Filling hose nitrogen bottle | |
| Length [m] | 3 |
| Nominal width [DN] | 8 |
| Connection | M20 x 1,5 [DKOS8, screw series 12S] Use gas bottle adapter from Roth filling and testing device |
| Filling hose of filling and testing device | |
| Length [m] | 6 |
| Nominal width [DN] | 8 |
| Connection | M20 x 1,5 [DKOS8, screw series 12S] Use gas bottle adapter from Roth filling and testing device |

For information on the permissible environmental conditions and the technical specifications of this Roth N2 charging unit including the materials used and sealing material as well as their resistance please see the documentation to the mounted parts.

3 Overview Roth N2 charging unit

The N2 charging unit essentially consists of the following components:

- | | |
|---|---|
| 1. Hydraulic aggregate complete | 1.9 Level indicator |
| 1.1 Check valve | 1.10 Tank |
| 1.2 Oil safety valve | 2. Compression accumulator (Piston accumulator) |
| 1.3 2/2-way directional seated valve | 2.1.1 Limit switch on oil side end cap |
| 1.4 Throttle valve | 2.1.2 Limit switch on gas side end cap |
| 1.5 Three-phase motor | 3. Electrical pressure switch |
| 1.6 Hydraulic pump | 4.1 Connecting hose inlet |
| 1.7 Tank lid (ventilation and exhaust filter) | 4.2 Connecting hose outlet |
| 1.8 Level switch (Level and temperature sensor) | 4.3 Connecting hose outlet |
| | 6. Check valve |

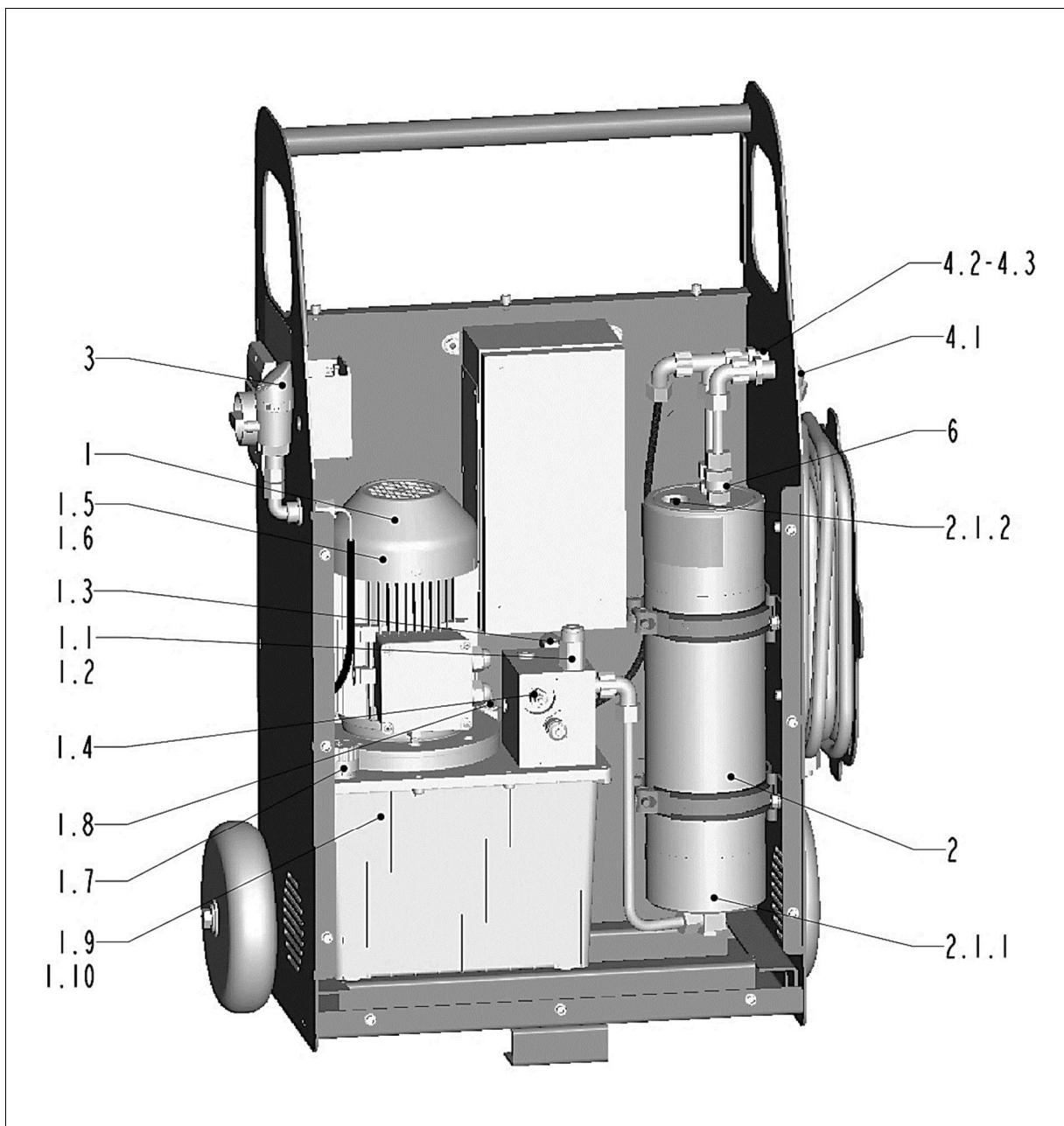

Figure 3-1 Overview of Roth N2 charging unit

Roth N2 charging unit electrical flow diagram:

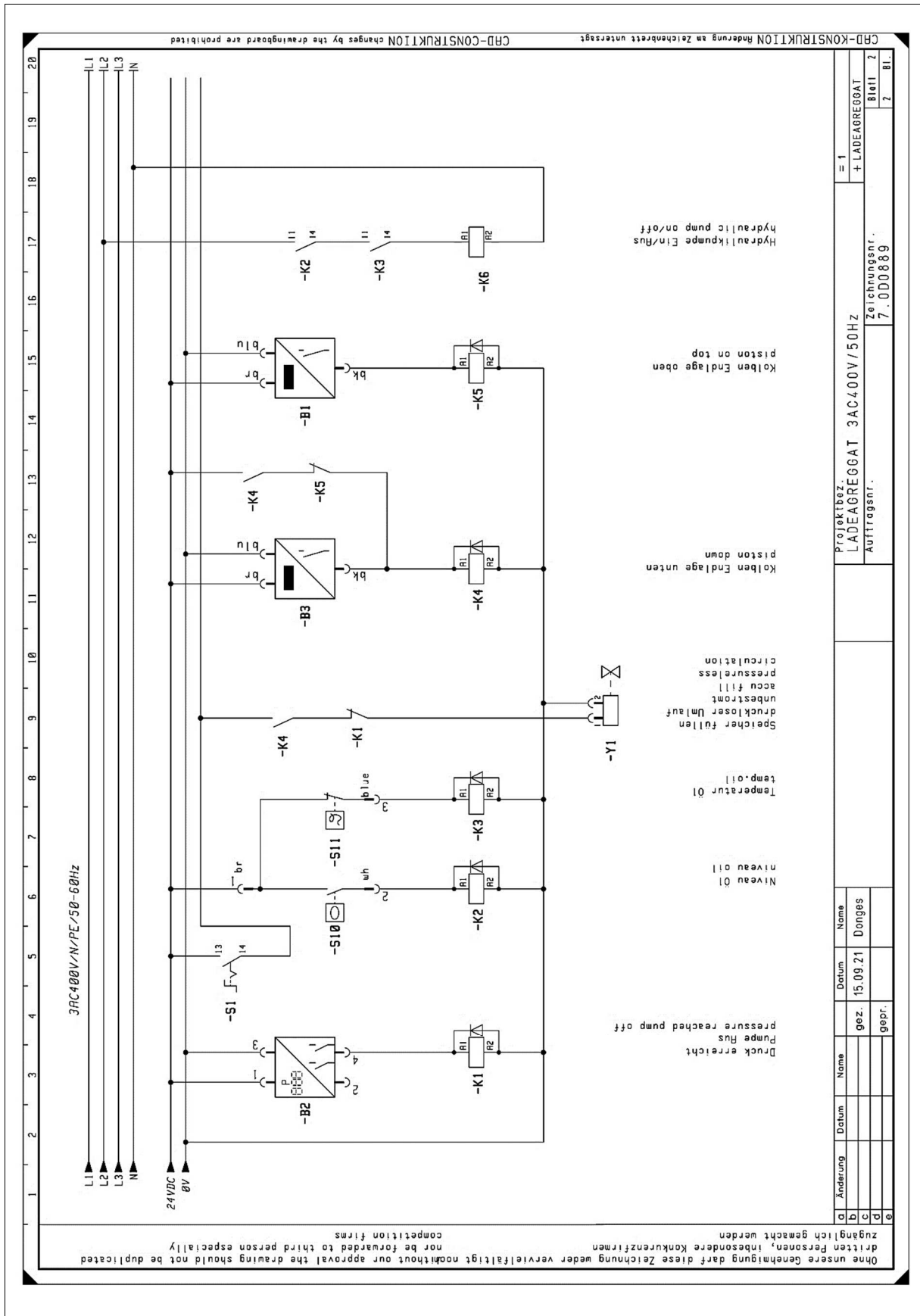

Figure 3-4

Roth N2 charging unit electrical flow diagram page 2 of 2

The Roth N2 charging unit comprises the following operating elements:

3. Electrical pressure switch
7. Main switch (ON = I / OFF = O)
8. Charging cycle Start/Stop switch



Figure 3-5 Overview of Roth N2 charging unit operating elements

4 Function principle



The items marked with [...] in the following description refer to section 3.

After the main switch (ON/OFF switch [7]) is switched to "ON", the pump [1.6] feeds the hydraulic oil in zero-pressure circulation via the 2/2-way switching valve [1.3] to the tank [1.10]. The electric pressure switch [3] it is also switched on to provide the desired gas prefill pressure (P_0) to the accumulator/system to be filled.

Turning the "Charging cycle Start/Stop switch" [8] to "Start" starts the charging cycle and the pump [1.6] pumps the hydraulic oil into the N2 compression accumulator [2]. This displaces the compressed nitrogen (N2) into the accumulator/system to be filled. The non-return valve [6] prevents the compressed N2 from being pumped back into the N2 bottle at the inlet.

The piston of the compression accumulator [2] travels until just before the end point of the gas-side nozzle, where an end switch [2.1.2] integrated into the nozzle sends the signal for switching the 2/2-way switching valve [1.3] into the tank [1.10] of the hydraulic unit. This relieves the pressure on the oil side of the compression accumulator [2] and N2 can once again flow in through the "N2 bottle intake" connection. The hydraulic oil is pushed back into the tank [1.10] of the hydraulic unit until the piston is positioned just in front of the oil-side nozzle. The pump [1.6] feeds the hydraulic oil in zero-pressure circulation into the tank [1.10].

An end switch [2.1.1] integrated into the oil-side nozzle gives the signal to switch the 2/2-way switching valve [1.3]. The pump [1.6] now once again feeds hydraulic oil into the compression accumulator [2] in order to once again charge/compress the inflow of N2. This process is repeated until the P_0 set on the electric pressure switch [3] is reached. When this pressure is reached, the hydraulic unit [1] switches off. The fill pressure can be read off on the pressure gauge on the filling and test unit.

The pump [1.6] is protected by an oil safety valve [1.2] which is set to a pressure of 250 (420) bar, depending on the design. In addition, a float switch [1.8] with an integrated temperature sensor is also fitted, and this switches off the N2 charging unit as soon as a temperature of 80 C is reached, or if the oil level in the tank [1.10] is too low. The N2 charging unit must be switched off at the ON/OFF main switch [7] and switched on again after an appropriate cooling time.

If the hydraulic unit [1] switches off during operation or does not start, this may be due to any of the following circumstances:

- The pressure (P_0) set on the electric pressure switch [3] has been reached.
- There is no/insufficient hydraulic oil in the tank [1.10] of the unit [1] (float switch [1.8]).
- The unit [1] switches off automatically if it overheats and can be returned to service once it has cooled down.

The pressure displayed on the electric pressure switch [3] corresponds to the nitrogen pressure in the compression accumulator [2]. The fill pressure in the accumulator/system to be filled is shown on the pressure gauge of the filling and test unit.



The cut-out pressure can differ from the pressure set on the electric pressure switch [3] due to the dynamic pressure of the connected components and the cross-section of the accumulator filling valve.

5 Safety

5.1 Notes / Explanations



Operating instruction, mandatory:

marked with a "book".



Warnings

marked with a warning triangle "danger".



Explosion:

marked with a warning triangle "explosion".



Notes:

marked with a "hand".

| | | | | | | | | | | | |
|---|---|--|---|---|--|---|--|--|--|--|--|
| | <p>Achtung Druckbehälter / Anlage</p> <p>- Vor Demontage Druck ablassen! - Füllen nur mit Stickstoff! - Betriebsanleitung beachten!</p> <p>GASFÜLLDRUCK BEI 293 K: _____ K</p> | | | <p>Attention Pressure vessel / Plant</p> <p>- Discharge pressure prior to disassembly! - Only fill with nitrogen! - Take note of operating instruction!</p> <p>GAS LOADED PRESSURE AT 293 K: _____ K</p> | | | <p>注意 压力容器 / 设备</p> <p>- 拆卸前先切断电压! - 只能充氮气! - 请注意操作手册!</p> <p>气侧预充压力 293 K: _____ K</p> | | | | |
| | <p>N2 bar He %</p> | | | <p>CZ Před demontáží vypusťte vzduch! Plnit pouze dusíkem! Respektujte návod k používání!</p> | | | <p>ES Descargar la presión antes del desmontaje! Llenar sólo con nitrógeno! Siga las instrucciones de uso!</p> | | | <p>FR Déchargement avant le démontage! Seulement remplissage d'azote! Attention le manuel d'utilisation!</p> | |
| <p>IT Prima del smontaggio togliere la pressione! Riempi solo con azoto! Osservare le istruzioni per l'uso!</p> | | | <p>NL Voor demontage de druk eraf halen! Alleen met Stikstof vullen! Gebruiksaanwijzing in acht nemen!</p> | | | <p>PL Przed demontażem wypuścić gaz! Napełniać tylko azotem! Przestrzegać instrukcję eksploatacji!</p> | | | | | |
| <p>PT Proceder à descarga da pressão antes de iniciar a desmontagem! Encher apenas com nitrogénio! Observe a instrução de operação!</p> | | | <p>RU Перед демонтажем сбросить давление! Заполнить только азотом, максимум! Руководствоваться инструкцией!</p> | | | <p>TR Sökmeden önce basıncı tahliye edin! Sadece azotla doldurun! Kullanma kılavuzunu dikkate alın!</p> | | | | | |

The compression accumulator [2] filled with N2 already, as given on the pressure equipment nameplate.

5.2 Identification / Nameplate

The Compression accumulator [2] and the N2 charging unit have a nameplate and acceptance certificate attached. These show essential technical data. The essential technical details are indicated on there.

The N2 charging unit is equipped with a CE sign for assemblies.

Please provide the following with all your enquiries:

- Indication of the type
- Serial number
- Date of manufacture

5.3 Safety systems



The safety systems may be included in the delivery or constitute part of the customer installation.

They will always be required and should be tested for effectiveness prior to commissioning.

5.3.1 Safety components on gas side



Ensure that the pressure set during the charging process is not changed!

If the operating pressure PS of the accumulator/system to be filled is lower than the operating pressure of the N2 charging unit (250 and/or 420 bar), additional gas-side protection of the pressure device must be provided.

If the pressure of the N2 bottle is higher than the maximum permitted pressure of the accumulator/system to be filled, or of the compression accumulator, pressure protection must be provided on the corresponding pressure device to safeguard this!

5.3.2 Safety components on oil side

The N2 charging unit **on oil side** (optional) features the following safety components:

Oil safety valve

The oil safety valve [1.2] protects of the compression accumulator [2] and the system parts such as pump [1.6] etc. It prevents the exceeding of the maximum operating pressure on the oil side of the pressure equipments and system components employed in the system (blow out capacity > pump flow rate).

The oil safety valve must be checked monthly. This must be done by means of a visual inspection.

A safety function part is the seal protecting against pressure adjustments

Check it for damages non-sealed parts must be removed by qualified personnel.

5.4 Safety precautions

The customer must instruct his operating and maintenance personnel in the use of the N2 charging unit and ensure that the safety precautions are being adhered to.

In principle, the responsible specialized superiors must instruct the operating, maintenance and servicing personnel prior to employment and first initial start-up of the pressure equipment and from that date on in appropriate time intervals but at least once a year. Maintenance, servicing as well as instruction measures must be recorded in a control book.

Qualified technician (definition based on EN 60204-1)

- A person who, based on specific training, knowledge and experience and knowledge of pertinent standards, will be in a position to assess assigned work and recognise potential hazards.

5.5 Responsibilities of the operator



The national implementations of framework Directive 89/391/EEC as amended and the associated individual directives, including specifically Directive 2009/104/EC as amended, on the minimum requirements for safety and health of employees working with work materials must be observed and complied within the EEA (European Economic Area).

The BetrSichV [Operational Safety Ordinance] transposes Directives 89/391/EEC, 2009/104/EC and other Directives on occupational safety at systems requiring supervision into German law. The BetrSichV, and especially Section 3, deals with the "Special requirements for systems requiring supervision" governing this pressure equipment. The operator is urged to familiarise itself with this section, since basic requirements are described here which the operator will be obligated to comply with!

The TRBS [Technical rules for operational safety], especially TRBS 3146, TRBS 2141 Parts 1-3, TRBS 1111, TRBS 1122 and TRBS 1201 Part 2 are other important guidelines that apply here. We recommend testing the surfaces for cracks near the thread and its transition in the course of internal routine testing in accordance with §16 and Annex 2, Section 4, Nos. 6.10 and 6.17. This is carried out ideally be performed by the manufacturer or by a “qualified person” designated by the manufacturer. Please refer to Chapter 9.2 for more detail.

Also ensure that the pressure equipment is not operated outside of the permissible range of operating pressures (see nameplate operating data). It is not permissible to operate the pressure equipment at pressures exceeding this.

Also ensure that local regulation on

- the safety of staff (accident regulations)
- the safety of working material (protective equipment and maintenance)
- product disposal (waste disposal laws)
- material disposal (waste disposal laws)
- cleaning (cleaning agents and disposal)
- and environmental protection

will be complied with.

Local regulations must be observed during installation and commissioning carried out by the operator itself (e. g. acceptance testing etc.).

6 Dangers

6.1 General hazard notes

Operations must remain within the maximum and minimum limits specified on the nameplate and in the technical documentation.

Any necessary safeguard for the accumulator/system to be filled and/or for the N2 bottle must be provided in such a way that the operating personnel are not put at risk by escaping operating materials when the safety equipment is triggered.

Structural modifications

Structural modifications to the N2 charging unit are prohibited. Mechanical reworking or welding is prohibited.

6.2 Installation of spare and wearing parts

The manufacturer's guarantees will lapse should parts that have not been tested or approved by the manufacturer be installed.



*Pressure-retaining components must only be replaced by or with the approval of the manufacturer.
Renewed acceptance testing by a notified body will be required!*

6.3 Cleaning, maintenance and repair work

Cleaning, maintenance or repair work may only be carried out by qualified technicians.

These activities require pressure must be relieved (on the oil and gas side), including securing against accidental switch-on.



When depressurizing on the gas side in closed rooms a good ventilation and / or air circulation of the room must be guaranteed.

Risk of suffocation when using nitrogen!!!

7 Commissioning



Commissioning and operation should only be performed by knowledgeable specialised personnel.

- Check that the N2 charging unit is intact.
- When using for the first time, fill in 10 liter oil (see chapter 9.1).
- Check the oil level through the sight glass [1.9] of the hydraulic unit [1].



420 bar variant:

The pump must be vented after each oil fill in order to prevent suction difficulties or air from entering the compression accumulator.

Unscrew the venting screw completely before filling. In this way, the air can escape from the inside of the pump during filling, and the oil level can rise unhindered. After filling, tighten the venting screw again (wait a few minutes if necessary).



If the operating pressure PS of the accumulator/system to be filled is lower than the operating pressure of the N2 charging unit (250 and/or 420 bar), additional gas-side protection of the pressure device must be provided.

If the pressure of the N2 bottle is higher at the N2 bottle inlet than the maximum permitted pressure of the accumulator/system to be filled, or of the compression accumulator, pressure protection must be provided on the corresponding pressure device to safeguard this!

7.1 Filling process preparations

Install a hose connection to the N2 bottle and the accumulator/system to be filled as shown in Figure 7-1.

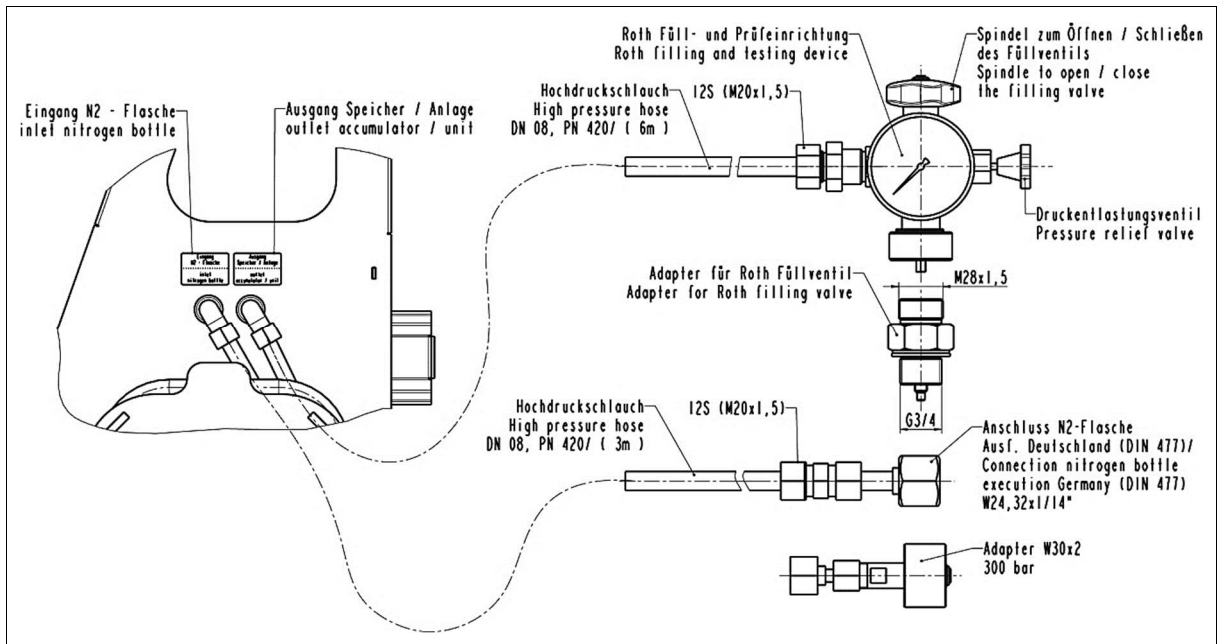

Figure 7-1 Connection view for nitrogen bottle and accumulator / unit



The operation and working methods given in the operating instructions for the Roth filling and test unit must be used.

- Connect the Roth filling and test unit to the accumulator/system to be filled.



Refer to the applicable operating instructions for the Roth filling and test unit for this (see section "Filling process preparations" Process no. 1-4.)

- Connect the "Accumulator/system output" connector hose on the N2 charging unit to the corresponding connector on the Roth filling and test unit.
- Connect the other connector hose, "N2 bottle input", on the N2 charging unit to the connection on the N2 bottle. You will need the appropriate N2 bottle adapter for this.



Check the filling hose for damages every time before filling. Take appropriate safety precautions to prevent any danger should the hose rupture. You may, for instance, run a tensioned steel cable parallel to the filling hose, joined to the hose in several places. Please note that the max. filling hose service life of ca. 6 years should not be exceeded.

- Complete Process no. 7 in accordance with the operating instructions for the Roth filling and test unit (see section "Filling process preparations"). The accumulator/system to be filled can now be filled with N2 and/or the N2 pressure can be tested.



Refer to the applicable operating instructions for the Roth filling and test unit for this!



The items marked with [...] in the following description refer to section 3.

- Check that the main switch [7] is switched to "OFF".
- Check that the "Charging cycle Start/Stop switch" [8] is set to "Stop".
- Establish a power supply with the power cable/plug.



Pay attention to the device connection voltage! Refer to the type plate on the N2 charging unit and the electrical circuit diagram!

An electrical connection (CEE plug) is provided for connection to a clockwise rotating field. The motor [1.5] / pump [1.6] rotates clockwise (see the direction of rotation arrow on the motor).

7.2 Filling process

- Open the valve on the N2 bottle on the "N2 bottle input". Nitrogen (N2) will now flow into the N2 compression accumulator [2] and into the N2 containment space of the accumulator/system to be filled until the pressure equalises. The pressure has equalised once the N2 flow is no longer audible, and the reading on the pressure gauge on the filling and test unit is no longer rising.

Switching on the N2 charging unit

- Switch the main switch [7] to ON. The motor [1.5] / pump [1.6] switches on, and circulates at zero pressure (no charging cycle / pressure build-up). The electric pressure switch [3] now indicates the N2 output pressure in the compression accumulator [2].



The direction of rotation of the motor [1.5] must be verified on the 230 bar variant of the N2 charging unit. Because of the design of the gear pump [1.6], the direction of rotation of the motor [1.5] must always be clockwise (to the right), otherwise the pump [1.6] will be unable to build up pressure and will be damaged.

You can perform this check by looking through the ventilation slots in the front panel, where you can see the direction of rotation from the direction of rotation of the fan wheel on the motor (clockwise).

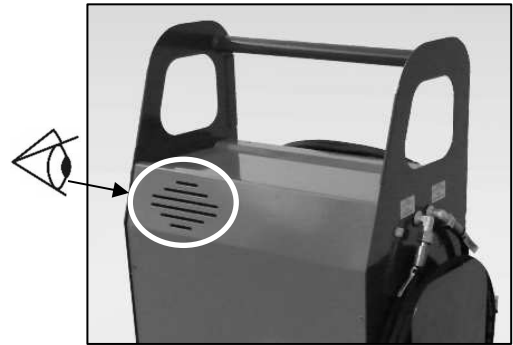

Setting the charging pressure P_0 on the electronic pressure switch

Pressing the button ▼ opens sub-menu SP1. Then, press button "M" and adjust the charging pressure P_0 in bar upward using button ▲ or downward using button ▼. When the required pressure is set, the display will flash. Press button "M" and the set charging pressure P_0 will be saved. The display will switch back to sub-menu SP1 and pressing button ▲ again will return you to the current pressure display for the N2 output pressure.

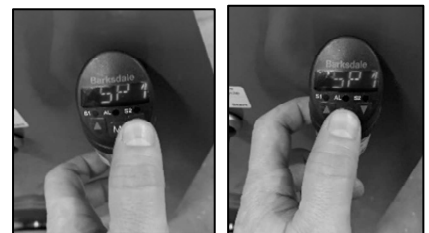



The associated operating instructions for the electric pressure switch [3] must be observed.



Ensure that the pressure set during the charging process is not changed!

Starting the charging cycle

- Switch the "Charging cycle Start/Stop switch" [8] to "Start".
- The charging cycle starts until the preset switching point SP1 is reached, and the hydraulic unit will then automatically switch off.
- Since pre-filling pressure (P_0) is temperature dependent and the N2 temperature will change during filling, the final P_0 reading will need to wait until the N2 temperature has approached that of the environment. This requires a waiting period of ca. 15 min.



Section 7.2.1 "Isochore behaviour of N2" must be observed in this regard.

- P_0 can be read off on the pressure gauge of the filling and test unit.
- Reduce P_0 to the correct value via the pressure relief valve, should it be too high. The N2 vessel valve must be closed.
- If P_0 is too low, the charging process can be repeated.
- If the input pressure of the N2 bottle is too low, such that the compression process does not result in a sufficient pressure increase in the accumulator/system to be filled, replace the N2 bottle with a bottle with a higher input pressure.

7.2.1 Isochore behavior of N2

Determining or controlling the pre-filling pressure (P_0) at different ambient temperatures

General

Unless otherwise specified, the given P_0 refers to room temperatures of + 20°C. Should the actual ambient temperature be different at the time of filling or checking P_0 , the diagram may be used to find the pressure corresponding to that temperature when filling or checking.

Example

Assume a gas system at 155 bar of pressure at a gas temperature of + 20°C. If the gas temperature rises to + 35°C, the intersection (155 bar at + 20°C) will shift to the next pressure-temperature curve to intersect the vertical + 35°C temperature line. The fill or corrected pressure P_0 will need to be 166 bar in this example.

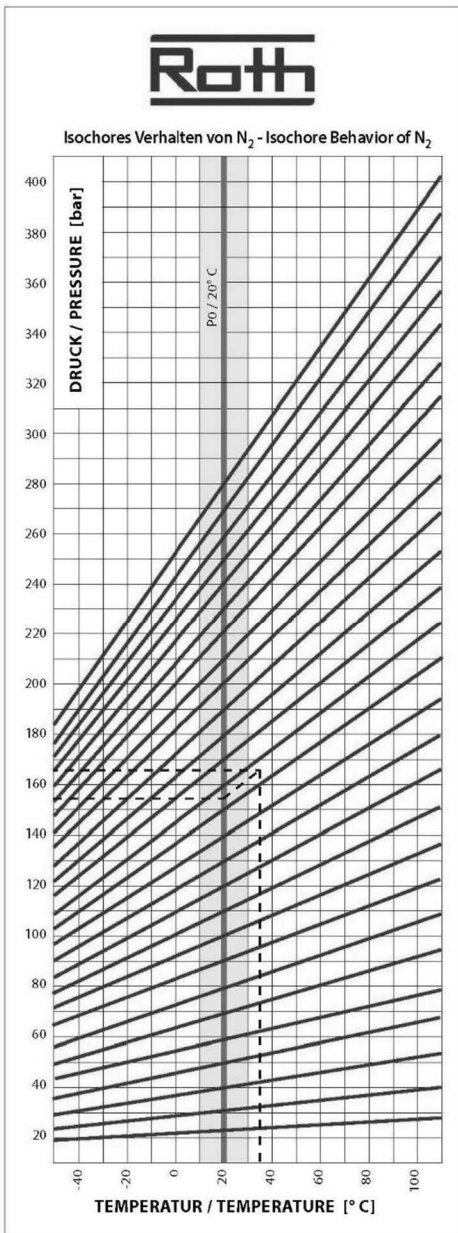

Figure 7-2 Isochore behavior of N2

7.3 Completing the filling process

- Switch the "Charging cycle Start/Stop switch" [8] to "Stop".
- Switch the main switch [7] to "OFF".



End the filling process in accordance with the operating instructions for the Roth filling and test unit, section "Completing the filling process", Process no. 11-15!

- Wait until the system is depressurised. Then, start loosening the connector hoses.



N₂ will escape!

Before loosening the hose lines, the displays on the pressure gauge of the filling and test unit and on the pressure switch must read "0 bar"!

8 Storage

The N2 charging unit is delivered to allow for storage up to 6 months.

Storage conditions

Closed and dry room according to the designated operating conditions.

Storage / packaging for further transport

The storage of the N2 charging unit and transport units, if necessary, accessories must take place in a way that the goods are protected against outside influences and damages.

Optimal short-time storage conditions:

- Dry rooms
- Protected from mechanical stress
- Seal off the connector hoses with locking plugs

The operator of the N2 charging unit may need to implement protective measures in cases of longer times in storage or unfavourable storage conditions. Please consult the manufacturer for relevant advice.

The connecting apertures of the N2 charging unit must be closed in transportation or storage, to prevent the intrusion of dirt or moisture and to prevent condensation.

Packaging for further transportation (change of location)

For an intended onward transport the N2 charging unit and its components must be packed in a way that mechanical damages can be avoided.



The components may need to be decontaminated before packaging for further transportation. Consult the datasheets for the fluids coming into contact with the components. Observe the notes on transportation and in the drawings.

9 Maintenance

9.1 General maintenance notes

In order to ensure trouble-free operation and a long service life for the N2 charging unit, the following maintenance tasks must be performed at intervals to be determined by the operator:

A **monthly** inspection is recommended. The intervals may be adjusted depending on experience gained.

- Check the accumulator anchoring.
- Check the connections of the lines.
- Inspect and assess the condition of the instrumentation, safety systems and seals.
- Check all screwed connections, shut-off valves, connections and joints for gas leakage using foaming agents.



Check the oil level via the sight glass of the N2 charging unit before each use.

- Check the oil filling.
- In case of refilling or new filling use hydraulic oils appropriate DIN 51524 TI. 1 until 3; ISO VG 10 until 68 acc. to DIN ISO 3448. Optimal operating viscosity: approx. 10...500 mm²/s
- The oil should be checked regularly depending on operation conditions. At least once a year, the oil should be drained, checked for contamination and possibly replaced.
Recommended hydraulic fluid purity in accordance with ISO 4406: 20/17/14...18/15/12.
Recommended filter unit $\beta_{6 \dots 16} \geq 75$.



For maintenance work at the N2 compression accumulator use the operating instruction of Roth piston accumulator.

9.2 Initial operating, repeated inspection and periods of repeated inspection

Initial operating

In Germany, the pressure equipment is subject to the Operational Safety Ordinance. §15 will apply to commissioning.

Repeated inspection

§16 of the Occupational Safety Ordinance sets the schedule for routine testing (pay attention to the according national directives of the set-up country, see Chapter 5.5).

Periods of repeated inspection

Roth Hydraulics GmbH recommends the following periods:

- External tests every 2 years
- Internal tests every 5 years
- Pressure tests depending on the number of load cycles, but after 10 years at least.

The customer must agree on the intervals of repeated inspection with the local authorities.

Initiation and execution

The operator must be responsible for compliance with and execution of period of repeated inspection (see Operational Safety Ordinance, Section 3).

10 Disassembling / disposal

Ensure that the N2 charging unit is depressurised on the gas and oil sides before disposal.

Sort the N2 charging unit by materials to be disposed in accordance with applicable local environmental regulations.

Decontaminate and dispose of any contaminated parts according to local environmental regulations.

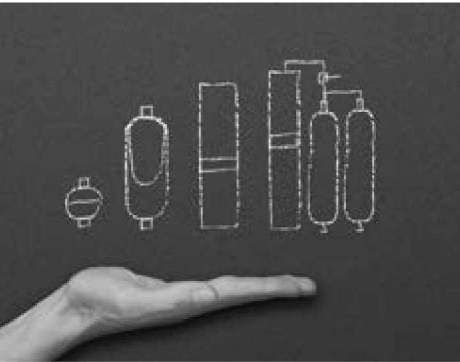

Roth Hydraulics

Accumulators

- > Diaphragm accumulators
- > Bladder accumulators
- > Piston accumulators

Accumulator systems

- > Accumulator units
- > Monitoring systems
- > System accessories
- > Pressure vessels

Special solutions

- > Spring accumulators
- > Damper systems
- > Rail hydraulics
- > Special accumulators

Roth
Hydraulics



ROTH Hydraulics GmbH
(former Bolenz & Schäfer GmbH)
Lahnstraße 34
D-35216 Biedenkopf-Eckelshausen
Germany
Phone: +49 (0) 6461 / 933-0
Fax: +49 (0) 6461 / 933-161
Email: service@roth-hydraulics.de
www.roth-hydraulics.de



ROTH Hydraulics (Taicang) Co., Ltd.
(former BSD Hydraulic Technology (Taicang) Co., Ltd.)
Building 14 A, No. 111,
Dongting North Road, Taicang City,
Jiangsu Province 215400, P.R. China
Phone: +86 (0) 512 / 53 20 88 36
Fax: +86 (0) 512 / 53 20 88 39
Email: service@roth-hydraulics.cn
www.roth-hydraulics.cn



ROTH Hydraulics NA Inc.
One General Motors Drive,
PO Box 245, Syracuse
New York 13211
USA
Phone: +1 (0) 315 / 4 75 01 00
Fax: +1 (0) 315 / 4 75 02 00
Email: service@roth-hydraulics.com
www.roth-hydraulics.com

**OPERATING INSTRUCTION
PISTON ACCUMULATOR**

Type: BA-AK-CE-EN
Language: English
Edition: 09-2016
Revision: 01

Translated from German original



General

Roth pressure equipment - identification

in accordance with the serial number on the nameplate and the according report, see

- Acceptance report, Pressure Equipment Directive 2014/68/EU
TÜV Technische Überwachung Hessen GmbH

Explanation

Roth piston accumulator = Roth pressure equipment

Translation

If sold to a country in the EEA, this operating instruction must be translated into the language of the country in which the machine is to be used.

Should the translated text contain incongruities, the original operating manual (German) must be consulted or the manufacturer contacted for clarification.

Copyright

No part of this publication may be reproduced, transmitted, sold or communicated without prior permission. Damages will be claimed for violations.

All rights reserved.

0 Contents

0.1 Table of Contents

| | | |
|-------|---|----|
| 0 | Contents | 1 |
| 0.1 | Table of Contents | 1 |
| 0.2 | Table of figures | 1 |
| 1 | Designated application | 2 |
| 1.1 | Overview of standard Roth pressure equipment | 2 |
| 1.2 | Notes on designated application | 3 |
| 2 | Function | 4 |
| 2.1 | General functional description | 4 |
| 2.2 | Filling and testing the pressure equipment | 4 |
| 2.2.1 | Isochore behavior of N ₂ | 5 |
| 3 | Safety | 6 |
| 3.1 | Notes / Explanations | 6 |
| 3.2 | Identification / Nameplate | 6 |
| 3.3 | Safety systems | 6 |
| 3.4 | Safety precautions | 6 |
| 3.5 | Responsibilities of the operator | 7 |
| 4 | Dangers | 8 |
| 4.1 | General hazard notes | 8 |
| 4.2 | Installation of spare and wearing parts | 8 |
| 4.3 | Cleaning, maintenance and repair work | 8 |
| 5 | Installation | 8 |
| 5.1 | Scope of delivery | 8 |
| 5.2 | Transport and packaging | 9 |
| 5.3 | Storage | 9 |
| 5.4 | Assembly / Commissioning | 10 |
| 6 | Maintenance | 11 |
| 6.1 | General maintenance notes | 11 |
| 6.2 | Initial operating, repeated inspection and periods of repeated inspection | 11 |
| 7 | Disturbance, causes, troubleshooting (qualified staff only) | 12 |
| 8 | Emergencies | 12 |
| 9 | Disassembling / disposal | 12 |
| | Notes | 13 |

0.2 Table of figures

| | | |
|------------|--|---|
| Figure 1-1 | Overview of standard Roth pressure equipment | 2 |
| Figure 2-1 | Isochore behavior of N ₂ | 5 |

1 Designated application

1.1 Overview of standard Roth pressure equipment

The pressure equipment essentially consists of the following components:

1. Cylinder tube
2. Piston inclusive seals
3. End cap
4. Threaded ring (not for screw-in end cap)
5. End cap seal, oil side
6. End cap seal, gas side
7. N2 non-return valve (optional)
8. Screw plug (optional)

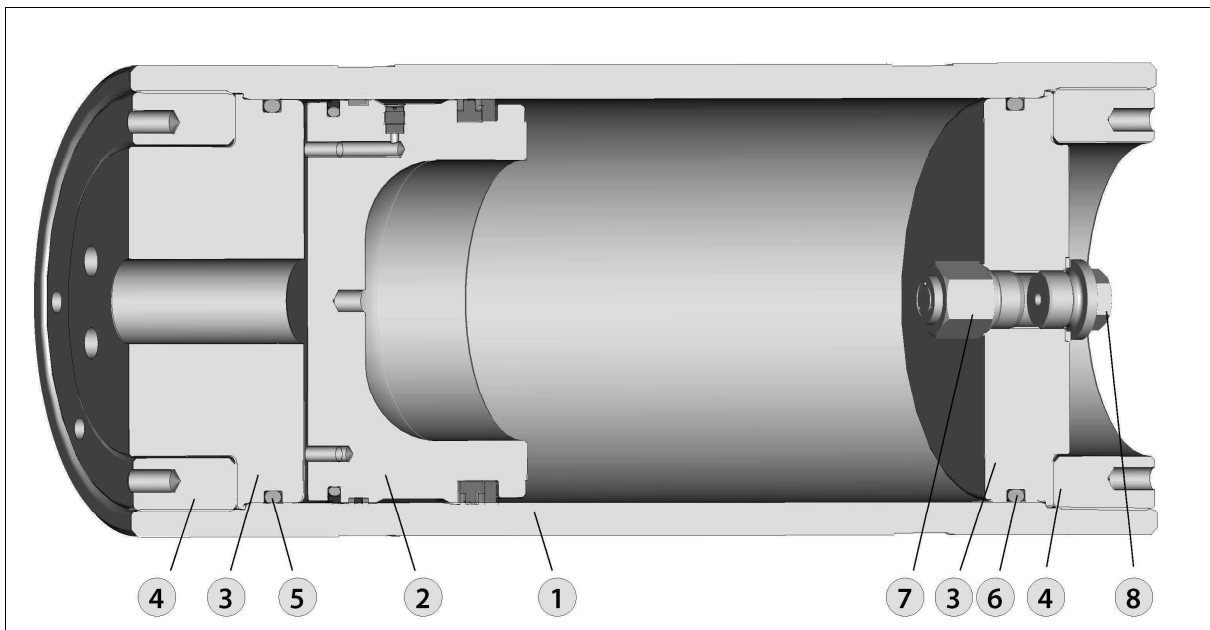

Figure 1-1 Overview of standard Roth pressure equipment

1.2 Notes on designated application

The Roth piston accumulator (Roth pressure equipment) was manufactured exclusively for use as an industrial and commercial component designed for acceptance and delivery of pressurised hydraulic fluids in hydraulic systems.

Any use of the pressure equipment other than or beyond as described above or any conversion by the operator or others shall be regarded as contrary to designated use, unless by prior written agreement of the manufacturer.

The manufacturer shall accept no liability for damages arising from this.

The pressure equipment may only be used with non-corrosive fluids in group 2 (Art. 13, PED 2014/68/EU) on the fluid side and with nitrogen (N₂) on the gas side. Wear allowance (e.g. corrosion) is not considered. Exceptions may result from the declaration of conformity or from individual manufacturer's specifications of the pressure equipment.

Pursuant to ISO 4406 the degree of purity of the operating fluid shall be at least 19/17/14 (NAS 1638 Class 8) for vertical installation and at least 17/15/12 (NAS 1638 Class 6) for horizontal installation, or better.

Depending on the mode of operation, stricter requirements might be necessary. Nitrogen (N₂) Class 4.0 (99.99%) or better shall be used.

If permissible load cycling are specified for specific pressure ranges in the acceptance documentation, the operator is responsible for compliance. If the pressure equipment is operated with different operating parameters, it is possible that the test intervals for periodic tests will become shorter. Please consult the manufacturer in such cases.



Intended use also includes compliance with the manufacturer's operating, maintenance and servicing instructions.

Furthermore, the operator is obliged to adhere to the legal state regulations according pressure equipments in connection with the adherence of the mandatory tests prior to commissioning and recurrent tests and must arrange these in compliance with the mandatory periods (see part 3.5).



The commissioning is prohibited until the entire system into which the pressure equipment will be installed has been certified compliant with EU directives.

The fluids required for operation of the pressure equipment is procured and used by the operator. Proper treatment of these fluids and the associated dangers are the sole responsibility of the operator.

Furthermore, the selections of a fluid are into consideration low-risk operation based on experience gained by the operator in the course of repeated use thereof in pressure equipment.

We recommend you also concluding guarantee agreements with suppliers of the fluids.

Please request written approval from the "manufacturer" in cases of special uses or if you have queries.

It is not permissible to interrupt / stop operation of the system in a way to allow the piston (see Fig. 1-1, Pos. 2) to hit the end cap of oil side (see Fig. 1-1, Pos. 3) at high speed (e.g. fast oil pressure release without end position damping)! This excludes emergency stop systems.

An internal test must be performed by an authorised inspection body (see AD 2000 leaflet p2, 12.3) on all pressure equipment with a specified number of permissible load cycles (load cycling number "N" for the defined pressure range $p_{min} - p_{max}$) no later than when 50% of the permissible number of cycles have been completed. The specialist may then define the extended number of load cycles. The term for permissible load cycles > 2 000 000 is fatigue strength. Pressure equipment may be operated without restriction in this pressure range.

2 Function

2.1 General functional description

Roth pressure equipments are cylindrical pressure vessels with a separating element between gas and fluid volumes (see Fig. 1-1).

They are used in hydraulic systems among others for energy accumulator. If the fluid pressure rises above the gas filling pressure, hydraulic energy is stored in fluid form. This may be utilised for work steps when the fluid pressure falls below the pressure of the compressed gas.

2.2 Filling and testing the pressure equipment



During or after filling with N₂, use foaming agents to test all screwed connections, shut-off valves, connections and joints for gas-tight sealing.



In principle, use Roth filling and testing device and observe the relevant operating instruction.

The pre-filling pressure (P_0) depends on the ambient temperature (isochore behavior of N₂, see Chapter 2.2.1) and should be 5 bar below the minimum operating pressure at maximum ambient temperature (unless otherwise specified).



Never use oxygen or other flammable gases to fill the pressure vessel.

2.2.1 Isochore behavior of N₂

Determining or controlling the pre-filling pressure (P₀) at different ambient temperatures

General

Unless otherwise specified, the given P₀ refers to room temperatures of + 20°C. Should the actual ambient temperature be different at the time of filling or checking P₀, the diagram may be used to find the pressure corresponding to that temperature when filling or checking.

Example

Assume a gas system at 155 bar of pressure at a gas temperature of + 20°C. If the gas temperature rises to + 35°C, the intersection (155 bar at + 20°C) will shift to the next pressure-temperature curve to intersect the vertical + 35°C temperature line. The fill or corrected pressure P₀ will need to be 166 bar in this example.

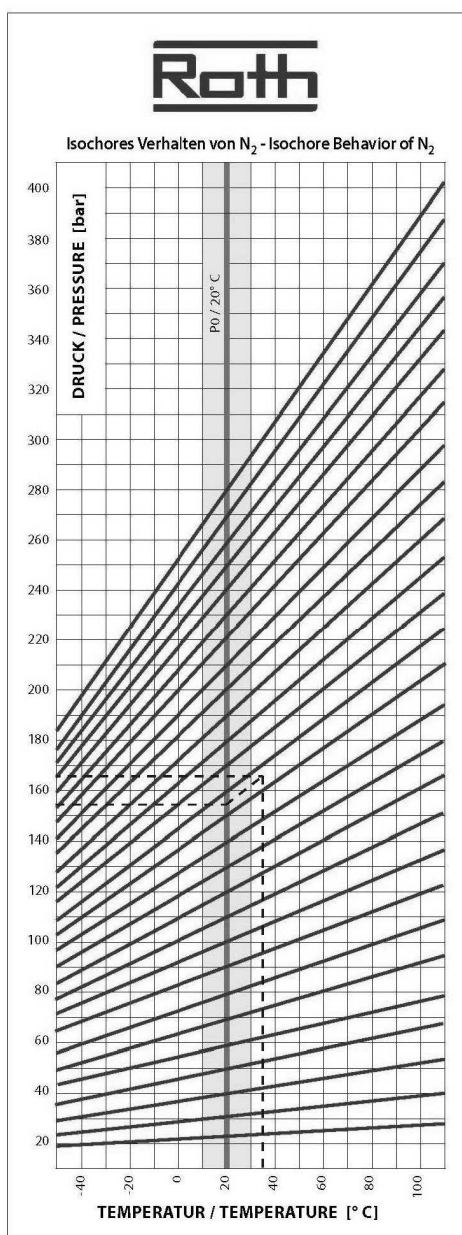

Figure 2-1 Isochore behavior of N₂

3 Safety

3.1 Notes / Explanations



Operating instruction, mandatory:

marked with a “book”



Warnings:

marked with a warning triangle “danger”.



Explosion:

marked with a warning triangle “explosion”.



Notes:

marked with a “hand”.

| | | |
|---|--|---|
| | | |
| <p>Achtung Druckbehälter / Anlage</p> <p>- Vor Demontage Druck ablassen! - Füllen nur mit Stickstoff! - Betriebsanleitung beachten!</p> <p>GASFÜLLDRUCK BEI 293 K:</p> | <p>Attention Pressure vessel / Plant</p> <p>- Discharge pressure prior to disassembly! - Only fill with nitrogen! - Take note of operating instructions!</p> <p>GAS LOADED PRESSURE AT 293 K:</p> | <p>注意 压力容器 / 设备</p> <p>- 拆卸前先切断电压! - 只能充氮气! - 请注意操作手册!</p> <p>气筒预充压力 293 K:</p> |
| <p>N2 bar He %</p> | | |
| <p>CZ Před demontáží vypusťte vzduch! Plnit pouze dusíkem! Respektujte návod k používání!</p> | <p>ES Descargar la presión antes del desmontaje! Llenar sólo con nitrógeno! Siga las instrucciones de uso!</p> | <p>FR Déchargement avant le démontage! Seulement remplissage d'azote! Attention le manuel d'utilisation!</p> |
| <p>IT Prima del smontaggio togliere la pressione! Riempi solo con azoto! Osservare le istruzioni per l'uso!</p> | <p>NL Voor demontage de druk eraf halen! Alleen met Stikstof vullen! Gebruiksaanwijzing in acht nemen!</p> | <p>PL Przed demontażem wypuścić gaz! Napełniać tylko azotem! Przestrzegać instrukcję eksploatacji!</p> |
| <p>PT Proceder à descarga da pressão antes de iniciar a desmontagem! Encher apenas com nitrogénio! Observe a instrução de operação!</p> | <p>RU Перед демонтажем сбросить давление! Заполнить только азотом, максимум! Руководствоваться инструкцией!</p> | <p>TR Sökmeden önce basıncı tahliye edin! Sadece azotla doldurun! Kullanma kılavuzunu dikkate alın!</p> |

The vessel filled with N2 already, as given on the pressure equipment nameplate.

3.2 Identification / Nameplate

The pressure equipment has a nameplate and acceptance certificate attached. These show essential technical data.

Please provide the following with all your enquiries:

- Indication of the type
- Serial number
- Date of manufacture

3.3 Safety systems



The safety systems may be included in the delivery (see delivery papers) or constitute part of the customer installation.

They will always be required and should be tested for effectiveness prior to commissioning.

3.4 Safety precautions

The operator shall instruct the operating and maintenance staff on the proper operation of the pressure equipment and monitor compliance with the safety precautions.

The responsible specialist superiors must instruct the operating, servicing and maintenance staff before starting in their jobs or prior to commissioning of the pressure equipment and thereafter at appropriate intervals of at least once per year. All services, maintenance and instruction courses must be recorded in a control book.

Qualified technician (definition based on EN 60204-1)

- A person who, based on specific training, knowledge and experience and knowledge of pertinent standards, will be in a position to assess assigned work and recognise potential hazards.

3.5 Responsibilities of the operator



The national implementations of framework Directive 89/391/EEC as amended and the associated individual directives, including specifically Directive 2009/104/EC as amended, on the minimum requirements for safety and health of employees working with work materials must be observed and complied within the EEA (European Economic Area).

The BetrSichV [Operational Safety Ordinance] transposes Directives 89/391/EEC, 2009/104/EC and other Directives on occupational safety at systems requiring supervision into German law. The BetrSichV, and especially Section 3, deals with the “Special requirements for systems requiring supervision” governing this pressure equipment. The operator is urged to familiarise itself with this section, since basic requirements are described here which the operator will be obligated to comply with!

The TRBS [Technical rules for operational safety], especially TRBS 3146, TRBS 2141 Parts 1-3, TRBS 1111, TRBS 1122 and TRBS 1201 Part 2 are other important guidelines that apply here. We recommend testing the surfaces for cracks near the thread and its transition in the course of internal routine testing in accordance with §16 and Annex 2, Section 4, Nos. 6.10 and 6.17. This is carried out ideally be performed by the manufacturer or by a “qualified person” designated by the manufacturer. Please refer to Chapter 6.2 for more detail.

Also ensure that the pressure equipment is not operated outside of the permissible range of operating pressures (see nameplate operating data). It is not permissible to operate the pressure equipment at pressures exceeding this.

Also ensure that local regulation on

- the safety of staff (accident regulations)
- the safety of working material (protective equipment and maintenance)
- product disposal (waste disposal laws)
- material disposal (waste disposal laws)
- cleaning (cleaning agents and disposal)
- and environmental protection

will be complied with.

Local regulations must be observed during installation and commissioning carried out by the operator itself (e.g. acceptance testing etc.).

4 Dangers

4.1 General hazard notes

Operations must remain within the maximum and minimum limits specified on the nameplate and in the technical documentation.

The pressure equipment must be installed ensuring that operating staff will not be endangered by escaping operating materials should parts of the safety system trigger.

Structural modifications

Structural modifications to the pressure equipment are prohibited. Mechanical reworking or welding is prohibited.

4.2 Installation of spare and wearing parts

The manufacturer's guarantees will lapse should parts that have not been tested or approved by the manufacturer be installed.



Pressure-retaining components must only be replaced by or with the approval of the manufacturer.

Renewed acceptance testing by a notified body will be required! The N2 concentration in the environment may increase when N2 is filled or drained. Adequate ventilation must be ensured.

4.3 Cleaning, maintenance and repair work

Cleaning, maintenance or repair work may only be carried out by qualified technicians.

These activities require that systems pressure must be relieved on the oil side, including securing against accidental switch-on.

The gas side pressure must also be relieved before performing work on gas side components.

5 Installation

5.1 Scope of delivery

The supplied pressure equipment / components include(s) technical documentation with operating instructions, drawings and the declaration of conformity (acceptance report by the notified body in case of individual acceptance tests).

Delivery

Incoming inspection:

- Check completeness as per the delivery note!

In case of damages:

- Check the delivery for damages (visual inspection)!

In case of complaints:

If the shipment damaged during transportation:

- Contact the most recent forwarder immediately!
- Keep the packaging (for possible inspection by the forwarder or for return shipment).

5.2 Transport and packaging

Ensure that the pressure equipment will not be damaged on the outside. Always ensure that the pressure equipment, should it need to be returned to the manufacturer, will not be pressurized.

Use suitable transport equipment for onward transportation or installation. Do not load the threaded bores on the face of the pressure equipment with more than the total weight given in the table. Using lashing straps for additional securing would be sensible. Consult the drawing for the weight of the pressure equipment or its components. Take note of the centre of gravity.

The permissible total weight of the pressure equipment for attachment of the slings to the threaded ring (see Fig. 1-1, Pos. 4) depends on the accumulator type series:

| Type series (diameter) | Fastening bores | Permissible total weight of the pressure equipment (see drawing) |
|------------------------|-----------------|--|
| 100 | 2 x M 8 | 500 kg |
| 180 | 2 x M 12 | 1500 kg |
| 250 | 2 x M 12 | 1500 kg |
| 360 | 2 x M 16 | 2000 kg |

5.3 Storage

Intermediate storage (packaged)

The pressure equipment and the spare and replacement parts are delivered to allow for storage up to 3 months.

Storage conditions

Closed and dry room according to the designated operating conditions.

Storage / packaging for further transport

The pressure equipment and any accessories must be stored to ensure that they will be protected from external factors and to exclude damage.

The manufacturer will protect all the components of the pressure equipment from corrosion, allowing for a time up to 3 months in storage.

Optimal short-time storage conditions:

- Dry rooms
- Protected from mechanical stress

The operator of the pressure equipment may need to implement protective measures in cases of longer times in storage or unfavourable storage conditions. Please consult the manufacturer for relevant advice.

The connecting apertures of the pressure equipment must be closed in transportation or storage, to prevent the intrusion of dirt or moisture and to prevent condensation.

The operator of the system must be on receipt of the pressure equipment assume responsibility for storage in accordance with these instructions. Lengthy periods in transport or storage whilst packaged should be avoided.

Packaging for further transportation (change of location)

The pressure equipment and its components should be packaged to exclude mechanical damage in the event of further transportation.



The components may need to be decontaminated before packaging for further transportation. Consult the datasheets for the fluids coming into contact with the components. Observe the notes on transportation and in the drawings.

5.4 Assembly / Commissioning

Setup / Installation

The assembly of the pressure equipment is to be carried out by qualified staff and must be specially trained for this kind of work.

A vertical arrangement with the oil side at the bottom is recommended. Different arrangements are likely to increase wear.

Use fastening hardware that is designed to handle the static and dynamic forces.

Welding or soldering on the pressure equipment or mechanical modification is **prohibited**.

No additional forces or moments are allowed to impact on the pressure equipment. The pressure equipment must **not** be exposed to flames or electrical / magnetic fields that may heat the equipment. Ensure that the cylinder tube (see Fig. 1-1, Pos. 1) of the pressure equipment will not be deformed or otherwise damaged when mounting the consoles / clamp.



Extensive damage may cause the pressure equipment to explode.

Do not install and operate the pressure equipment in rooms that are unprotected against lightning and earthquakes.

Depending on operation, surface temperatures capable of causing burns may occur at the limits of operating conditions. The operator should provide suitable protection.

Consult Chapter 6 for service notes and test schedules.

Use the **fastening hardware** provided by the manufacturer to ensure that all parts will be securely fastened.

Before assembly:

- Check the delivery for transport damage to ensure that it is technically intact.
- Instruct the qualified staff.

Prior to commissioning, the operator should:

- Check the technical documentation for completeness as per Chapter 5.1.
- Completion of the infeed and outfeed systems and the **parts of the system** into which the pressure equipment will be incorporated that have a **safety functionality**.
- Ensuring the functionality of installed instrumentation.



The operator should have the entire system acceptance tested (see Chapter 3.5) before commissioning the pressure equipment.

Observe Chapters 2 and 4 when filling or draining.

Uninstalling the pressure equipment

Measure and ensure that the oil and gas sides are depressurised before uninstalling.

6 Maintenance

6.1 General maintenance notes

The pressure equipment will be largely maintenance-free after filling.

To ensure perfect operation and long life of the pressure equipment, carry out the following services to the schedule specified by the operator.

A **monthly** inspection is recommended. The intervals may be adjusted depending on experience gained.

- Check the accumulator anchoring.
- Check the connections of the lines.
- Inspect and assess the condition of the instrumentation, safety systems and seals.
- Check all screwed connections, shut-off valves, connections and joints for gas leakage using foaming agents.
- Check the N₂ pre-filling pressure (P_0) to prevent the piston (see Fig. 1-1, Pos. 2) from colliding with the gas-side end cap (see Fig. 1-1, Pos. 3).

6.2 Initial operating, repeated inspection and periods of repeated inspection

Initial operating

In Germany, the pressure equipment is subject to the Operational Safety Ordinance. §15 will apply to commissioning.

Repeated inspection

§16 of the Occupational Safety Ordinance sets the schedule for routine testing (pay attention to the according national directives of the set-up country, see Chapter 3.5).

Periods of repeated inspection

Roth Hydraulics GmbH recommends the following periods:

- External tests every 2 years
- Internal tests every 5 years
- Pressure tests depending on the number of load cycles, but after 10 years at least.

The customer must agree on the intervals of repeated inspection with the local authorities.

Initiation and execution

The operator must be responsible for compliance with and execution of period of repeated inspection (see Operational Safety Ordinance, Section 3).

7 Disturbance, causes, troubleshooting (qualified staff only)

| Disturbance | Cause | Troubleshooting |
|---|--|---|
| Pressure equipment system will not supply hydraulic fluid | <ul style="list-style-type: none"> Shut-off valve closed Pressure relief open Gas-side pressure too low | <ul style="list-style-type: none"> Open shut-off valve Close pressure relief valve Check the charging pressure |
| Hydraulic pressure too low | <ul style="list-style-type: none"> Shut-off valve closed Pump does not deliver | <ul style="list-style-type: none"> Open shut-off valve Check the pump functionality and repair, if necessary |
| N2 safety valve triggers | <ul style="list-style-type: none"> Gas-side pressure too high Operation has markedly increased the gas temperature Fluid overflow | <ul style="list-style-type: none"> Check charging pressure and plant settings Find reason for temperature rise Depressurise pressure equipment |

8 Emergencies

This pressure equipment is a passive system, without own drives. The stored energy will be charged or discharged by the connected active system of the operator.

Emergency measures such as the operation of Emergency-Off systems or fast pressure relief action should therefore preferably be defined and documented in the work instructions of the operator.

9 Disassembling / disposal

Ensure that the pressure equipment is depressurised on the gas and oil sides before disposal.

Sort the pressure equipment by materials to be disposed in accordance with applicable local environmental regulations.

Decontaminate and dispose of any contaminated parts according to local environmental regulations.

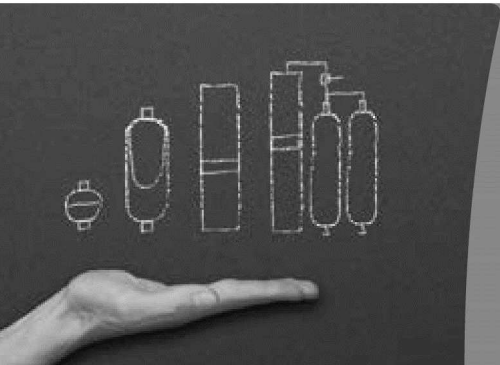

Roth Hydraulics

Accumulators

- > Diaphragm accumulators
- > Bladder accumulators
- > Piston accumulators

Accumulator systems

- > Accumulator units
- > Monitoring systems
- > System accessories
- > Pressure vessels

Special solutions

- > Spring accumulators
- > Damper systems
- > Rail hydraulics
- > Special accumulators

Roth
Hydraulics



ROTH Hydraulics GmbH
(former Bolenz & Schäfer GmbH)
Lahnstraße 34
D-35216 Biedenkopf-Eckelshausen
Germany
Phone: +49 (0) 6461 / 933-0
Fax: +49 (0) 6461 / 933-161
Email: service@roth-hydraulics.de
www.roth-hydraulics.de



ROTH Hydraulics (Taicang) Co., Ltd.
(former BSD Hydraulic Technology (Taicang) Co., Ltd.)
Building 14 A, No. 111,
Dongting North Road, Taicang City,
Jiangsu Province 215400, P.R. China
Phone: +86 (0) 512 / 53 20 88 36
Fax: +86 (0) 512 / 53 20 88 39
Email: service@roth-hydraulics.cn
www.roth-hydraulics.cn



ROTH Hydraulics NA Inc.
One General Motors Drive,
PO Box 245, Syracuse
New York 13211
USA
Phone: +1 (0) 315 / 4 75 01 00
Fax: +1 (0) 315 / 4 75 02 00
Email: service@roth-hydraulics.com
www.roth-hydraulics.com

**OPERATING INSTRUCTION
FILLING AND TESTING DEVICE**

Type: BA-FPE-EN
Language: English
Edition: 12-2016
Revision: 01
Translated from German original



General

Translation

When supplying to countries in the EEA, the Operating Instructions must be translated into the language of the user country.

In the event of inconsistencies in the translated text, please consult the original operating instruction (German) or contact the manufacturer.

Copyright

No part of this publication may be reproduced, transmitted, sold or communicated without prior permission. Damages will be claimed for violations.

All rights reserved.

0 Contents

0.1 Table of Contents

| | | |
|-----|---------------------------------|---|
| 0 | Contents | 1 |
| 0.1 | Table of Contents | 1 |
| 0.2 | Table of figures | 1 |
| 1 | Roth filling and testing device | 2 |
| 1.1 | Filling process | 3 |
| 1.2 | Pressure relief | 5 |

0.2 Table of figures

| | | |
|------------|---------------------------------|---|
| Figure 1-1 | Roth filling and testing device | 2 |
|------------|---------------------------------|---|

1 Roth filling and testing device

Description:

The filling and testing device serves to check the N2 pressure and to fill Roth pressure equipment's / accumulator systems with N2.

The filling and testing device (1) consist of:

- 1.1 Filling hose connection (with non-return valve)
- 1.2 Accumulator connection
- 1.3 Pressure gauge
- 1.4 Pressure relief valve
- 1.5 Spindle to open / close the fill valve
- 2 Filling hose DN8 (length 1500 mm) / DN2 (length 3000 mm)
- 2.1 Roth N2 vessel adapter (FA1 ... FA8)
- 3 Roth filling valve adapter (A1 ... A4)

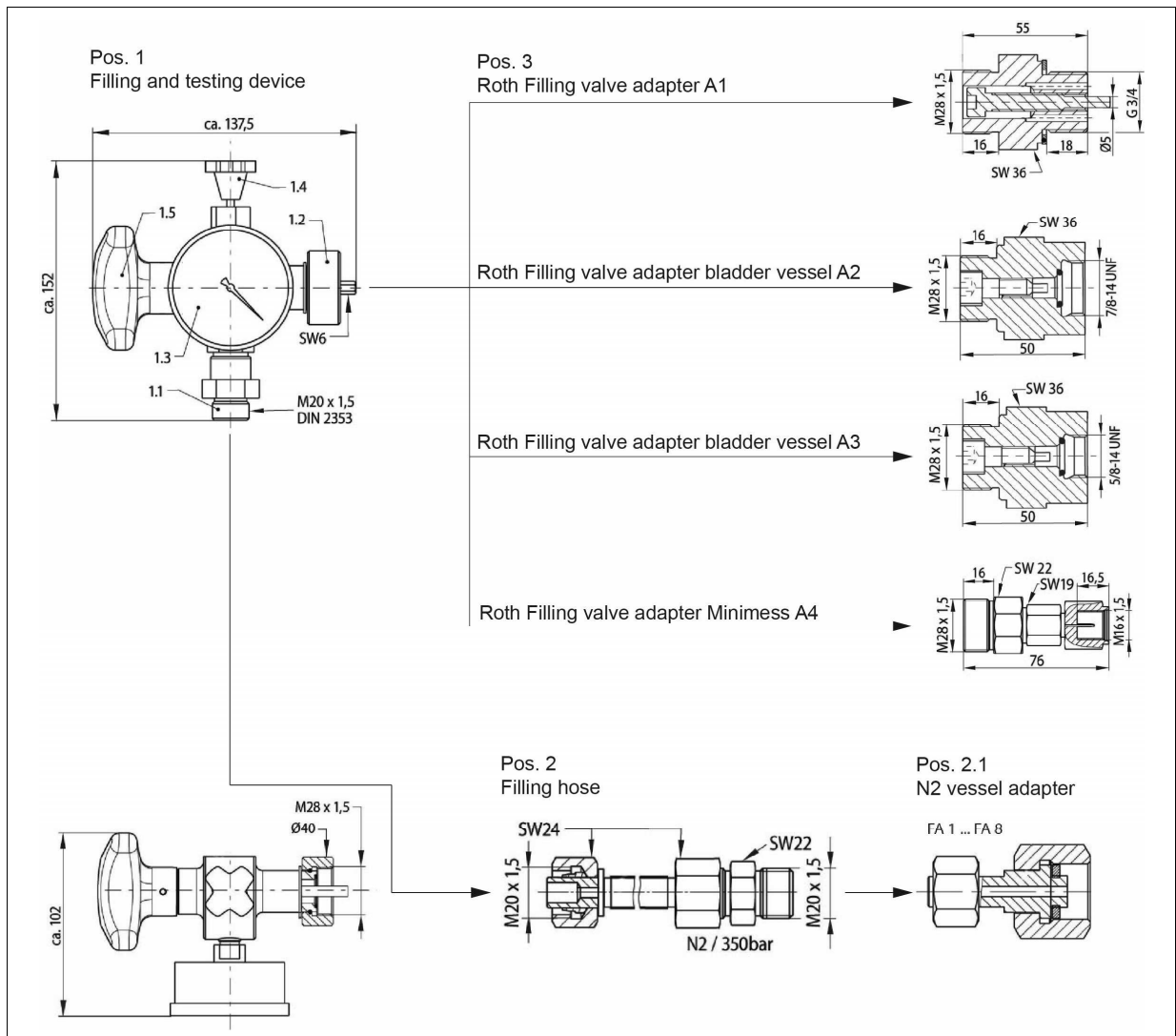



Figure 1-1 Roth filling and testing device

1.1 Filling process

The filling and testing device (see Fig. 1-1, Pos. 1) may only be operated by trained qualified staff in accordance with the work instruction below.

Please reference the flow diagram and list of equipment for filling.

Filling process preparations

| Process step | with Roth filling valve adapters A1, A2, A3 (see Fig. 1-1, Pos. 3) | with Roth filling valve adapter Minimes A4 (see Fig. 1-1, Pos. 3) | without filling valve adapter |
|---|--|--|--|
| 1. | Remove the sealing plug and seal of the filling valve on the pressure equipment. | Remove the sealing cap of the Minimes filling valve on the pressure equipment. | Remove the sealing plug and seal of the filling valve on the pressure equipment. |
| 2. | Rotate the spindle of pressure relief valve (Fig. 1-1, Pos. 1.4) on the filling and testing device (Fig. 1-1, Pos. 1) clockwise up to the stop (closed). | | |
| 3. |  <p>Use the previously removed seal of the sealing plug for filling valve adapter A1, A2, A3 and screw the filling adapter into the threaded bore provided for the filling process.</p> <p><i>Make sure that the cylinder screw of filling valve adapter will not prematurely open the filling valve on the pressure equipment whilst screwing in. Screw the cylinder screw far enough out to prevent premature opening of the filling valve adapter.</i></p> | First connect the Minimes filling valve adapter A4 to the filling and testing device. The hexagonal rod will not be functional in this configuration. | - |
| 4. | Now screw the filling and testing device connection on to the filling valve adapter A1, A2, A3. Make sure that the hexagonal rod of the filling and testing device locks into the cylinder screw of the filling valve adapter. | Now screw the Minimes filling valve adapter with the filling and testing device on to the Minimes filling valve of the pressure equipment. The Minimes filling valve will open automatically whilst screwing in. | Now screw the filling and testing device connection directly on to the filling valve of the pressure equipment to fill. Make sure that the hexagonal rod of the filling and testing device locks into the cylinder screw of the filling valve. |
| 5. | Connect the corresponding filling hose connection (Fig. 1-1, Pos. 2) to the connection point of the filling and testing device. | | |
| 6. |  <p>Connect the other end of the filling hose (Fig. 1-1, Pos. 2) to the connection of the N2 vessel. You will need the corresponding N2 vessel adapter FA1 ... FA8 to do this (Fig. 1-1, Pos. 2.1).</p> <p><i>Check the filling hose (Fig. 1-1, Pos. 2) for damages every time before filling. Take appropriate safety precautions to prevent any danger should the hose rupture. You may, for instance, run a tensioned steel cable parallel to the filling hose, joined to the hose in several places. Please note that the max. filling hose service life of ca. 6 years should not be exceeded.</i></p> | | |
| 7. | Rotate the spindle (Fig. 1-1, Pos. 1.5) clockwise up to the stop to open the filling valve adapter. The pressure equipment can then be filled with N2 or the N2 pressure tested. | The pressure equipment can then be filled with N2 or the N2 pressure tested. | Turn the spindle (Fig. 1-1, Pos. 1.5) anticlockwise up to the stop to open the filling valve. The pressure equipment can then be filled with N2 or the N2 pressure tested. |
| If you only want to check the nitrogen pressure, you can skip points 5 and 6. | | | |

Filling with N2

| Process step | with Roth filling valve adapters A1, A2, A3 (see Fig. 1-1, Pos. 3) | with Roth filling valve adapter Minimess A4 (see Fig. 1-1, Pos. 3) | without filling valve adapter |
|---|---|--|-------------------------------|
| 8. | Keep the N2 cylinder valve open until the pressure gauge shows the required pre-filling pressure (P_0). With the filling valve open, P_0 may also be read off on the pressure equipment or accumulator systems gas side pressure gauge, if existing. To read P_0 , the N2 vessel adapter (Fig. 1-1, Pos. 2.1) must be closed from time to time. | | |
| 9. | Since P_0 is temperature dependent and the N2 temperature will change during filling, the final P_0 reading will need to wait until the N2 temperature has approached that of the environment. This requires a waiting period of ca. 15 min. | | |
| 10. | Reduce P_0 to the correct value via the pressure relief valve (Fig. 1-1, Pos. 1.4), should it be too high. The N2 vessel valve must be closed. | | |
|  | <i>If the pressure of the N2 vessel is higher than the maximum permissible pressure of the pressure equipment and the pressure equipment itself does not have a pressure protection device, it is necessary to connect a pressure limiter in between to protect the pressure equipment.</i> | | |

Completing the filling process

| Process step | with Roth filling valve adapters A1, A2, A3 (see Fig. 1-1, Pos. 3) | with Roth filling valve adapter Minimess A4 (see Fig. 1-1, Pos. 3) | without filling valve adapter |
|--------------|--|--|---|
| 11. | Close the N2 vessel adapter after filling is complete. | | |
| 12. | Turn the spindle (Fig. 1-1, Pos. 1.5) of the filling and testing device anticlockwise up to the stop. This closes the filling valve in the pressure equipment or the accumulator system. | Now unscrew the Minimess filling valve adapter with the filling and testing device from the Minimess filling valve of the pressure equipment. The Minimess filling valve will close automatically as it is unscrewed. <i>The residual pressure in the filling device and in the filling hose (Fig. 1-1, Pos. 2) will audibly escape via the Minimess filling valve adapter, since manual pressure relief via the pressure relief valve (Fig. 1-1, Pos. 1.4) is not possible here. Depending on the length of the filling hose, this procedure may take a while. Only loosen the screwed connection completely after full release of the pressure.</i> | Rotate the spindle (Fig. 1-1, Pos. 1.5) of the filling and testing device clockwise, to its stop. This closes the filling valve in the pressure equipment or the piston accumulator system. |
| 13. | Open the pressure relief valve (Fig. 1-1, Pos. 1.4) to release the pressure in the filling and testing device. | - | Open the pressure relief valve (Fig. 1-1, Pos. 1.4) to release the pressure in the filling and testing device. |
| 14. | You may now detach the filling and testing device and any filling valve adapter you may have used. | | |
| 15. | Retighten the sealing plug and seal (steps 1 and 2). (use only the original screw plug with pressure relief). | | |

Potential problems and solutions:

Should the pressure in the pressure equipment and the N2 vessel equalise before P_0 is reached, filling of the pressure equipment must terminate (inadequate pressure in the N2 vessel).

Changing the N2 vessel:

- Carry out steps 11 to 13. Unscrew the N2 vessel adapter (see Fig. 1-1, Pos. 2.1) from the filling hose (Fig. 1-1, Pos. 2.1) on the empty N2 cylinder and attach the filling hose to a full N2 vessel.
- You may now continue filling the pressure equipment from step 7 onwards, as described.

1.2 Pressure relief



Pressure relief of the oil side is to be carried out by the operator.

Pressure relief of the gas side

| Process step | with Roth filling valve adapters A1, A2, A3 (see Fig. 1-1, Pos. 3) | with Roth filling valve adapter Minimes A4 (see Fig. 1-1, Pos. 3) | without filling valve adapter |
|--------------|---|---|---|
| 1. | See steps 1 to 4, Chapter 1.1. | | |
| 2. | Slowly rotate the spindle (Fig. 1-1, Pos. 1.5) clockwise. The filling valve in the pressure equipment will open and N2 flows into the filling and testing device. | - | Slowly rotate the spindle (Fig. 1-1, Pos. 1.5) anticlockwise. The filling valve in the pressure equipment will open and N2 flows into the filling and testing device. |
| 3. | Rotate the pressure relief valve (Fig. 1-1, Pos. 1.4) anticlockwise to release N2. | | |
| 4. | Make sure that the pressure equipment of the gas side is depressurised. The pressure gauge will in this case show 0 bar. Leave the pressure relief valve (Fig. 1-1, Pos. 1.4) in open position. | | |
| 5. | Repeat the procedure should the system still have over-pressure. | | |

Additional steps for accumulator systems

Pressure relief of the gas side (with N2 vessel)

- Close the N2 shut-off device between the connected N2 vessel and the pressure equipment.

Additional steps as described under Point 1.2.



The N2 vessel remain under pressure up to the N2 shut-off unit. Simply skip step 1 to depressurise the latter also.

Roth Hydraulics

Accumulators

- > Diaphragm accumulators
- > Bladder accumulators
- > Piston accumulators

Accumulator systems

- > Accumulator units
- > Monitoring systems
- > System accessories
- > Pressure vessels

Special solutions

- > Spring accumulators
- > Damper systems
- > Rail hydraulics
- > Special accumulators

Roth
Hydraulics



ROTH Hydraulics GmbH

(former Bolenz & Schäfer GmbH)
Lahnstraße 34
D-35216 Biedenkopf-Eckelshausen
Germany
Phone: +49 (0) 6461 / 933-0
Fax: +49 (0) 6461 / 933-161
Email: service@roth-hydraulics.de
www.roth-hydraulics.de



ROTH Hydraulics (Taicang) Co., Ltd.

(former BSD Hydraulic Technology (Taicang) Co., Ltd.)
Building 14 A, No. 111,
Dongting North Road, Taicang City,
Jiangsu Province 215400, P.R. China
Phone: +86 (0) 512 / 53 20 88 36
Fax: +86 (0) 512 / 53 20 88 39
Email: service@roth-hydraulics.cn
www.roth-hydraulics.cn



ROTH Hydraulics NA Inc.

One General Motors Drive,
PO Box 245, Syracuse
New York 13211
USA
Phone: +1 (0) 315 / 4 75 01 00
Fax: +1 (0) 315 / 4 75 02 00
Email: service@roth-hydraulics.com
www.roth-hydraulics.com